

# POWER SPLITTERS

## For Removing Frozen Nuts The Right Way



### Features / Benefits :

- Safe - No sparks. No flames. No risk to volatile surroundings. No hammers or impact needed. No flying fragments.
- Fast - Cuts a 3" nut in 20 to 30 seconds vs. approx. 20 minutes with a hammer & chisel or torch.
- Easy Set up - You can be up and away in less than 5 minutes.
- Quiet - No noise pollution or related injuries. You will only hear the hum of the hydraulic pump and a snap when the nut is cut.
- No Damage to bolt or stud threads by calibrating the chisel so that only the nut is cut.
- Versatile - Power splitters cut the hardest nuts. The range of models offered and the range of each model compares very favorably vs. the competition.
- Price - Competitive price of the unit plus savings in reduced downtime and no damage to costly bolts and studs.

### Power Splitter

Model - AS-105  
to  
Model - AS-506

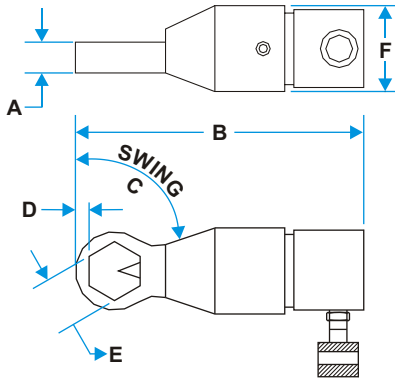

### Power Splitter Angle Headed

Model - AS-100

For removing  
Frozen nuts  
the right way.  
Other Anglesplitter  
sizes quoted on  
request.

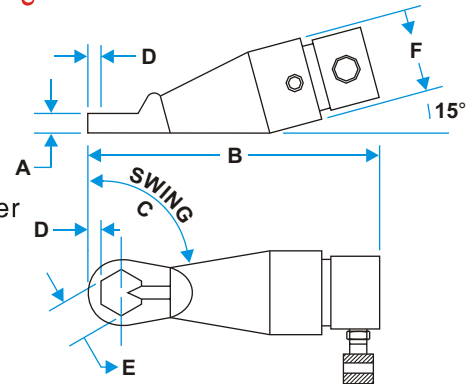

Model No.	Stud Diameter		Nut A/F  Across The Flats		A		B		C	D		E		F		Weight	
	mm	inch	mm	inch	mm	inch	mm	inch		mm	inch	mm	inch	mm	inch	kg	lbs
AS-100 Angleheaded	11-16	7/16-5/8	13-24	1/2-1	17.5	11/16	260.0	10.1/4	30°	6.0	1/4	27.0	1.1/16	72.5	2.7/8	3.76	8.20
AS-105	11-22	7/16-7/8	16-36	5/8-1.7/16	38.1	1.1/2	271.0	10.7/16	60°	9.5	3/8	38.1	1.1/2	105.0	4.1/8	9.82	21.60
AS-200	22-32	7/8-1.1/4	36-51	1.7/16-2	38.1	1.1/2	287.0	11.5/16	45°	12.7	1/2	54.0	2.1/8	108.0	4.1/4	10.42	22.90
AS-204	32-38	1.1/4-1.1/2	46-60	1.13/16-2.3/8	57.1	2.1/4	385.0	15.5/32	30°	14.3	9/16	63.5	2.1/2	164.0	6.7/16	32.50	71.50
AS-210	35-45	1.3/8-1.3/4	57-70	2.1/4-2.3/4	57.1	2.1/4	398.0	15.11/16	30°	17.5	11/16	73.0	2.7/8	164.0	6.7/16	32.86	72.30
AS-308	45-57	1.3/4-2.1/4	70-89	2.3/4-3.1/2	77.8	3.1/16	460.0	18.1/8	30°	19.0	3/4	98.4	3.7/8	214.0	8.7/16	72.12	158.66
AS-314	50-64	2-2.1/2	79-98	3.1/8-3.7/8	79.4	3.1/8	488.0	19.7/32	30°	22.2	7/8	108.0	4.1/4	214.0	8.7/16	74.52	163.94
AS-404	64-70	2.1/2-2.3/4	95-108	3.3/4-4.1/4	95.3	3.3/4	579.0	22.13/16	60°	28.6	1.1/8	117.5	4.5/8	250.8	9.7/8	114.18	251.20
AS-500	76-83	3-3.1/4	114-127	4.1/2-5	104.8	4.1/8	590.0	23.7/32	60°	28.6	1.1/8	136.5	5.3/8	250.8	9.7/8	116.62	256.56
AS-506	83-89	3.1/4-3.1/2	124-136	4.7/8-5.3/8	104.8	4.1/8	598.0	23.17/32	60°	28.6	1.1/8	149.2	5.7/8	250.8	9.7/8	119.50	262.90

\* If you have an application not covered by the models above just call us and we will probably be able to design a model for you.



# POWER SPLITTERS

## Power Splitter Vs. the competition :

- Versatile - One model cuts a wide range of nut sizes (6-8) Vs. 1-2 of the competition. Hydraulic Cylinders and other common parts among models reduce inventory (refer parts list below for common parts).
- Flexible - Housing is designed to fit virtually any application so you can work from more angles and in tighter spaces. Power Splitter fits all API and ANSI flanges and all valve bonnets. It cuts virtually any shape nut (Hex, square and 12 point).
- Durable - Our heat treatment processes and cryogenic treatment of housings and chisels ensure life second to none. Chisels can be resharpened after dozens of cuts to prolong life.
- Precise - Chisel can be calibrated by using suitable holder to cut the nut wall precisely so that the bolt or stud does not get damaged. No damage to your equipment and no damage to your Power Splitter.
- Power - Power to weight ratio is the best in the industry and it is easier to handle.
- Economical - Price is among the most competitive available anywhere in the world.
- Warranty - For a full 6 months from defects in materials or workmanship.
- Variety of Pumps - Power splitter can be supplied with a variety of hand, foot operated, electric or air powered pumps. Please contact us for choices of available pumps.

## Power Splitter Part List :

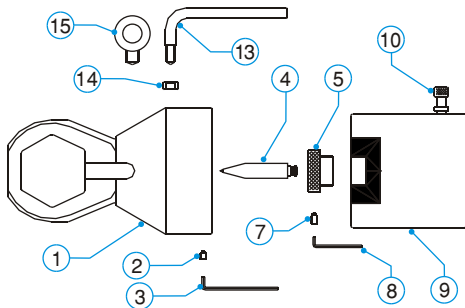

**TYPE 1**  
POWER SPLITTER with externally threaded chisel holders; used in nut splitters with internal threads in the piston rod.

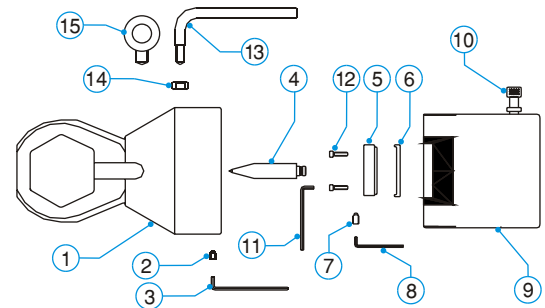

**TYPE 2**  
POWER SPLITTER that have a cylinder with threaded bolt holes in the piston rod and chisels holders that use socket head cap screw.

Sr. No.	Description	Model									
		Type 1							Type 2		
		AS100	AS105	AS200	AS204	AS210	AS308	AS314	AS404	AS500	AS506
1	Housing										
2	Set Screw										
3	Allen Wrench										
4	Chisel										
5	Chisel Holder										
6	Spacers Set										
7	Set Screw for Chisel Holder										
8	Allen Wrench for Chisel Holder										
9	Hydraulic Cylinder										
10	Quick Disconnect Female Coupler										
11	Allen Wrench for Cap Screws										
12	Socket Head Cap Screw (2 each)										
13	Handle for Housing (2)										
14	Hex Nut for Handle (2)										
15	Lifting Eye										
16	Tool Box (Not Shown)										

Note : Shades overlapping into multiple model numbers indicate common parts.