

# TUBE END FACING MACHINE

## FM-1625

The FM-1625 is light weight and powerful machine for facing, bevelling, and weld preparation. It is compact, easy for handling and quick setup. It is used for jobs in restricted access area.

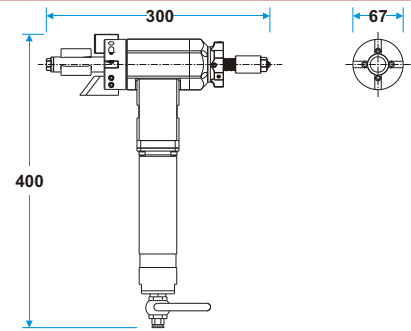

Drive	Pneumatic	Electric
Locking Range (mm)	20 - 42	20 - 42
Idal Speed (RPM)	400	250
Torque (Nm)	27.5	45.0
Feeding Stroke (mm)	23	23
Pneumatic Power (HP)	0.45	--
Air Consumption (cfm)	16	--
Air Pressure (psi)	90	--
Electric Power (watts)	--	59.5
Weight (kg)	4.5	5.5

### CUTTING BITS

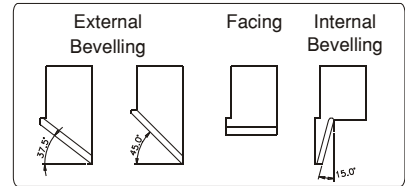

## FM-3000

The FM-3000 is a very popular versatile and powerful machine. Quick interchangeability of locking jaws to suit wide range of dia meters. Modular and ergonomic design.

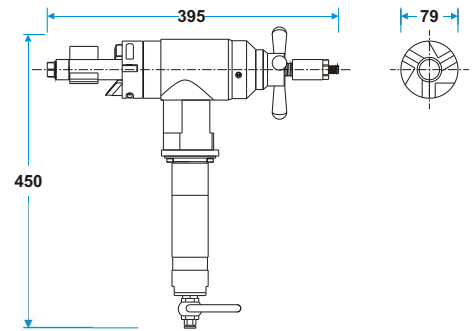

Drive	Pneumatic	Electric	Hydraulic
Locking Range (mm)	28 - 76	28 - 76	28 - 76
Idal Speed (RPM)	110	140	192
Torque (Nm)	84	138	140
Feeding Stroke (mm)	40	40	40
Pneumatic Power (HP)	0.83	--	--
Air Consumption (cfm)	42	--	--
Air Pressure (psi)	90	--	--
Electric Power (watts)	--	595	--
Weight (kg)	10.5	16.0	15.6

### CUTTING BITS

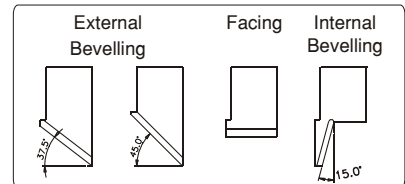

## FM-4500

The FM-4500 is a heavy duty machine design to bevel face and weld age preparation for heavy wall thickness tubes. Modular and ergonomic design.

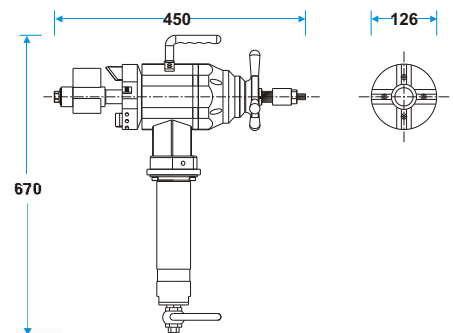

Drive	Pneumatic	Electric
Locking Range (mm)	39 - 104	51 - 203
Idal Speed (RPM)	40	40
Torque (Nm)	220	240
Feeding Stroke (mm)	40	40
Pneumatic Power (HP)	0.9	--
Air Consumption (cfm)	40	--
Air Pressure (psi)	90	--
Electric Power (watts)	--	1800
Weight (kg)	24.0	27.0

### CUTTING BITS

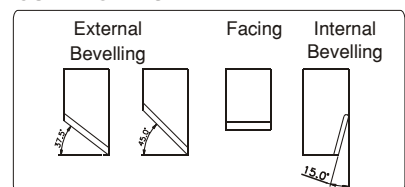

# TUBE END FACING MACHINE

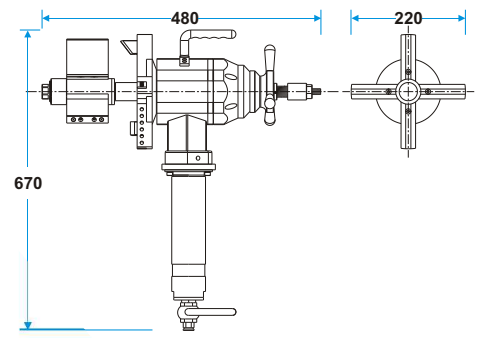
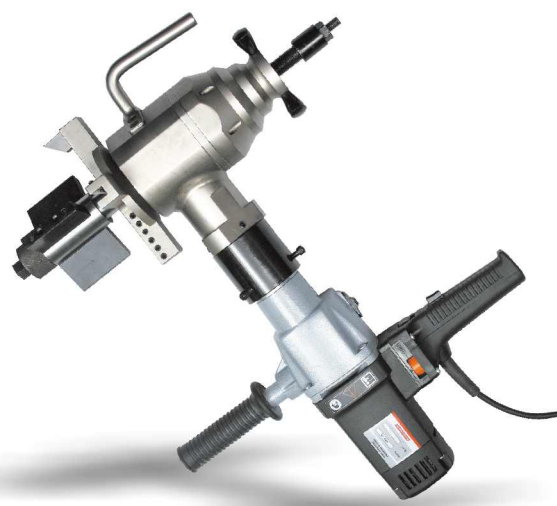

## FM-8000

The FM-8000 is a heavy duty machine with wide range tube ID. design to bevel face and weld age preparation for heavy wall thickness tubes. Modular and ergonomic design with high torque to suit in toughest heavy duty working condition.

Drive	Pneumatic	Electric
Locking Range (mm)	51 - 203	51 - 203
Ideal Speed (RPM)	40	40
Torque (NM)	220	240
Feeding Stroke (mm)	40	40
Pneumatic Power (HP)	0.9	--
Air Consumption (cfm)	40	--
Air Pressure (psi)	90	--
Electric Power (watts)	--	1800
Weight (Kg)	26.5	30.0

### CUTTING BITS

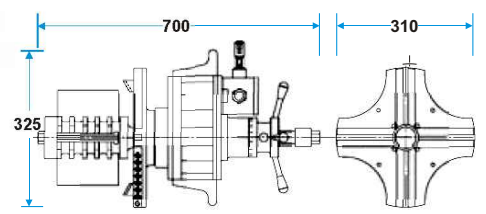
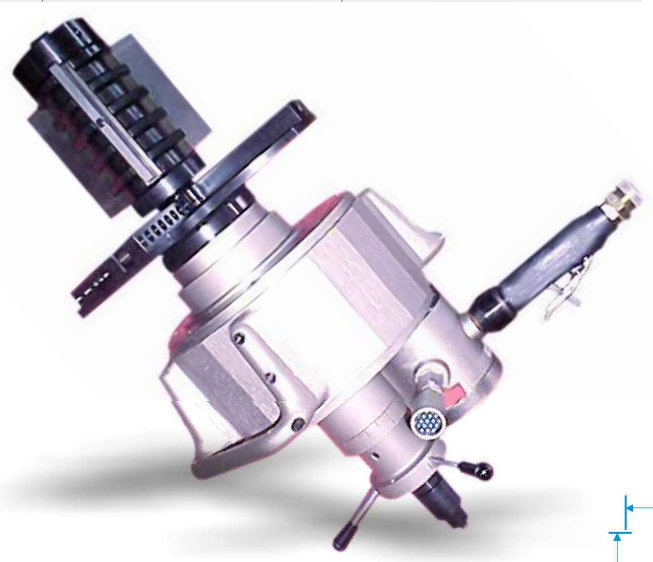
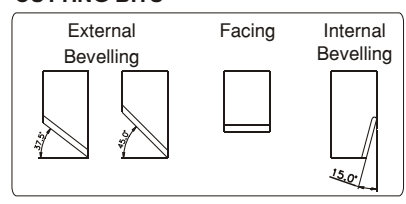

## FM-12000

The FM-12000 is a combination of power and range in light and portable design. Wide range for tube end facing, beveling, counter boring and weld edge preparation. Rugged and balance machine suitable for all types of steels.

Drive	Pneumatic	Electric
Locking Range (mm)	100 - 306	100 - 306
Ideal Speed (RPM)	35	31
Torque (Nm)	180	230
Feeding Stroke (mm)	50	50
Pneumatic Power (HP)	1.88	--
Air Consumption (cfm)	60	--
Air Pressure (psi)	90	--
Electric Power (watts)	--	1400
Weight (kg)	43.0	44.0

### CUTTING BITS

